



Growing Grapes

IN WEST VIRGINIA



*West Virginia Department
of Agriculture*

Table of Contents

Introduction	1
Types of Grapes	1
Locating the Vineyard	2
Soil	2
Temperature.....	3
Obtaining the Plant	4
<i>Hardwood Cutting</i>	5
<i>Layering & Grafting</i>	5
<i>Root Stock</i>	6
<i>Cultivars</i>	6
Planting the Vineyard	7
<i>Soil Preparation</i>	7
<i>Layout</i>	7
Vineyard Soil Culture	9
<i>Weed Control</i>	9
<i>Cover Crops</i>	9
<i>The Hillside Vineyard</i>	9
<i>Fertilizer</i>	10
Training & Pruning	11
<i>Training Young Vines</i>	11
<i>Principles</i>	11
<i>Flower-Cluster Thinning</i>	12
<i>Systems</i>	13
Trellising	15
<i>Two-Wire Vertical Trellis for Grapes</i>	15
<i>Geneva Curtain-Type Trellis for Grapes</i>	17
Harvesting	18
Pest Management	18
<i>Deer</i>	19
<i>Disease</i>	19
<i>Insects</i>	19
<i>Other Disorders</i>	21
Seeded Table Cultivars	22
Wine Table Cultivars	24
Appendices	26
<i>Appendix 1a</i>	27
<i>Appendix 1b</i>	29
<i>Appendix 1c</i>	31

————— **Contact Information** —————

Plant Industries Division

Phone: 558-2212

Fax: 558-2435

Regulatory & Environmental Affairs

Phone: 558-2208

Fax: 558-3594

Pesticide Regulatory Programs Unit

Phone: 558-2209

Fax: 558-2228

Communications Division

Market Bulletin

Phone: 558-3708

Fax: 558-3131

marketbulletin@wvda.us

Executive Division

Phone: 558-3200

Fax: 558-2203

agriculture.wv.gov

Kent A Leonhardt
Commissioner of Agriculture

Stations ^w	Years Data ^x	GDD ^y	Average occurrence of low temperature in 10 years ^z				
			-5° F	-6° to -10° F	-11° to -15° F	<-15° F	
Spruce Knob	33	2264	37	31	11	5	
Summersville	19	2885	39	33	13	3	
Terra Alta	18	2303	38	31	11	5	
Union	34	2798	14	10	3	1	
Vienna Briscoe	8	3433	5	4	1	0	
Wardensville	38	2958	18	15	5	1	
Wayne	7	3223	19	14	4	1	
Webster Springs	35	3205	16	13	5	1	
Weirton	26	3398	8	5	1	0	
Wellsburg	35	3106	21	20	7	1	
Weston	26	3398	8	5	1	0	
West Union	12	2978	40	30	14	4	
Wheeling	25	3259	7	4	2	0	
White Sulphur Springs	36	3198	9	7	3	1	
Williamson	32	3836	7	4	1	0	
Winfield Locks	36	3583	6	5	1	0	

Growing Grapes in West Virginia

Grapes are grown in West Virginia in small-scale commercial and backyard plantings. The increased interest in grapes for table and wine production has led to increased research and cultivar selection by the Division of Plant and Soil Sciences of the West Virginia University Davis College of Agriculture, Forestry and Consumer Science. With careful planning and management, grapes can be grown in West Virginia for home or profitable commercial use.

Types of Grapes

There are several hundred widely different cultivars of grapes grown in the United States. The cultivars are grouped into four types: (1) European (*Vitis vinifera*), (2) American (*Vitis labrusca* and its derivatives), (3) Muscadine (*Vitis rotundifolia*) and (4) French hybrids, crosses of *V. vinifera* cultivars with disease-resistant wild American species.

The European grape has been difficult to grow in West Virginia because it is very susceptible to cold injury and requires long, warm summers for proper fruit maturation. Disease and insect susceptibility are also serious problems with *V. vinifera* types. With proper site selection and training systems to allow recovery from winter damage, European grapes can be grown in some areas of West Virginia. Wineries prefer *vinifera* grapes for wine production and will often pay a premium price for them.

The American grape typified

by the cultivar Concord is winter hardy and disease resistant. American grapes are the most commonly grown grapes east of the Rocky Mountains. Many new cultivars of excellent seedless table grapes, very different from Concord, have been developed.

Muscadine grapes are most commonly grown in the south because they are only hardy where temperatures rarely fall below 10, F (-12°C). Few places in West Virginia meet this requirement. The fruit and culture of Muscadine grapes is different from other grapes and will not be covered in this paper.

French hybrids are usually superior to American types for wine and are more cold hardy and disease resistant than European types. Several of these cultivars have been tested in West Virginia for their adaptability to eastern climatic conditions (see section on cultivars).

Locating the Vineyard

Proper site and soil selection are critical to good production. The prospective grape grower is in most cases already on a farm and has little if any choice in the general location for a vineyard, but the grower may have several possible sites available on the farm from which to choose. The vineyard should be located away from natural woodlands, if possible, to reduce infestation by insects and damage by birds and deer. It is important that the site have good air and water drainage. The slope should be gentle enough to allow easy cultivation and spraying without erosion. A level piece of land with lower land nearby so that cold air can drain off, or a site that has a slope of 2-3 feet in each 100 feet is ideal. Steeper sites should

be planted with rows following the contour. Good air drainage is more essential with grapes than with other small fruits because, in addition to possible frost injury, infection by such fungus diseases as black rot is more severe where air drainage is poor.

The most desirable exposure must be decided by the individual grower. A southern exposure gives an earlier crop but increases the danger of injury to the tender shoots from late spring frost. A northern or eastern exposure reduces the risk of frost but gives a later crop. The grower must decide if the slightly earlier crop is worth the risk. Market demands will be an important consideration in making the choice.

Soil

A gravelly or sandy loam soil is considered best for grapes, but they will do well on many soil types. The soil should have a fairly high water-holding capacity, not be waterlogged at any time during the year, have 3 to 5 feet of usable depth depending on texture, be of at least medium fertility and slightly acid. A soil too poor to grow other crops will not be satisfactory for a vineyard. The prospective grower

should keep certain general characteristics of soils in mind in choosing a site. A sandy soil warms up rapidly and will mature a crop a few days earlier than will a clay soil but a sandy soil tends to be less fertile and to have a smaller water-holding capacity. A soil containing too much clay will also form a crust in hot weather that will adversely affect water infiltration.

Appendix 1c. Growing degree days and frequency of low temperatures from various weather stations throughout West Virginia.

Station ^w	Years Data ^x	GDD ^y	Average occurrence of low temperatures in 10 years ^z			
			-5° F	-6° to -10° F	-11° to -15° F	<-15° F
Piedmont	15	3253	3	3	1	0
Pike Island	6	3324	12	8	3	0
Pineville	36	3367	12	9	2	1
Point Pleasant	9	3405	13	10	3	2
Rainelle	5	2734	8	6	0	0
Ravenswood	26	3567	13	10	3	2
Reedsville	9	2539	36	30	14	3
Richwood	5	2400	22	16	8	2
Ripley	33	3635	17	14	7	2
Romney	30	3268	15	14	3	1
Rowlesburg	37	2928	21	16	5	2
Seneca	20	2229	63	51	23	7
Shady Springs	3	2386	17	10	7	0
Sinks of Gandy	4	1654	85	75	43	20
Spencer	36	3385	18	14	5	3

Stations ^w	Years Data ^x	GDD ^y	Average occurrence of low temperature in 10 years ^z			
			-5° F	-6° to -10° F	-11° to -15° F	<-15° F
Lewisburg	31	2948	10	7	2	1
Logan	33	3935	7	5	1	0
London Locks	35	3621	6	5	1	0
Madison	37	3673	12	10	2	0
Mannington	28	3076	36	31	13	5
Mathias	35	2828	17	14	4	1
Martinsburg	38	3423	6	4	2	0
McRoss	29	2487	41	36	15	4
Middlebourne	37	3215	29	24	11	4
Moorefield	28	3555	15	12	5	1
Morgantown	37	3320	10	8	4	1
New Cumberland	33	3286	14	11	3	1
New Martinsville	23	3606	7	6	1	0
Oak Hill	38	2902	19	15	4	1
Parkersburg	38	3567	8	6	2	1
Parsons	29	2709	31	25	9	3
Petersburg	20	3471	7	5	2	1
Pickens	32	2297	45	38	14	7

Temperature

In selecting a grape cultivar, you must consider the number of growing degree days, the length of the growing season and the frequency of exposure to low temperatures. The time required to mature grape fruit varies with location and climate and is very dependent on the amount of heat experienced by the vine. The frequency of very cold weather will determine winter survival of the vines.

The growing degree day (GDD) is used to calculate the amount of heat received. It is calculated as the daily average temperature (max + Min/2) minus the base temperature of 50 F below which grapes will not grow. During a spring day with a high of 80 F and a low of 60 F, the GDD+((80+60)/2)-50=20. The whole month of average 70 F weather would be equal to 600 GDD (30 days x 20=600). You can approximate the number of GDD

from the closest weather reporting station (see appendix 1). For every 100 feet elevation, the GDD decreases by approximately 70 for a season. If a nearby town experiences 3000 GDD in a year and your vineyard is 200 feet higher, then your vineyard would have approximately 2860 GDD (3000-(70 x 2)).

In general a frost free period of 165-180 days is required to mature grape fruit and wood. The period must be long enough to allow harvest of the fruit and time for the wood to acclimate for the winter. The length of the growing season is not as important as the GDD in determining cultivar adaptability, as some areas with long seasons are not warm enough to mature grapes well. Wine growing regions are divided into five zones based solely on their GDD accumulations:

Table 1. Wine growing regions, their GDD and typical cultivars.

Region	GDD	Cultivars
I	>2500	Chardonnay, Pinot, Noir, White Riesling, Foch, Cayuga, White, most American types
II	2501-3000	Above cultivars and Chambourcin, Chenin Blanc, Cabernet Sauvignon, Gamay, Seyval, Vidal 256
III	3001-3500	Chenin Blanc, Refosco, Zinfandel, Seyval, Vidal 256
IV	3501-4000	Dessert wines, table grapes, raisin grapes
V	>4000	Thompson Sdls.

Table 2. The expected ten-year frequency of cold temperatures related to winter damage hazard.

Minimum Temperature			Winter Damage Hazard
-5	-10	-15	
<4	1	0	Excellent for all cultivars
<6	1	Long Term Min.	Good for all but cold tender cultivars
Every Year	<5	1	Medium or greater hardiness required
Every Year	>5	>3	Unsuitable

Determining which region your vineyard falls into will not directly determine which cultivars to choose. Winter hardiness (frequency of exposure to -5 F°), disease and general adaptability make recommendations impossible. Winter damage hazard may be estimated by the frequency of low temperatures (Table 2). If you have no experience with a variety, establish only a few vines and observe them for a few years. This experience will be invaluable when you are ready to plant and train a full vineyard. Appendix 1 gives GDD and low temperature frequencies for several weather stations throughout West Virginia.

Obtaining the Plants

The commercial grape grower will usually find it is most satisfactory to obtain plants from a dependable nursery. If vigorous one-year-old plants are purchased, the grower will get healthy stock with a well-developed fibrous root system. Such vines will grow rapidly in the vineyard and will repay the extra cost because they bear more quickly and give greater returns over a period of years. A vineyard is a long-term investment. It is not worthwhile to try to economize by starting with questionable stock. Purchasing the young vines has the further advantage of saving the grower the year's time that is necessary to obtain a rooted plant from a cutting. Nursery plants which are

two years old or more are often those that were too weak for selling at the end of one year and may grow poorly in the vineyard.

For a person who simply desires a few plants for the home garden and for a commercial grower who plans far enough in advance, home propagation requires the least outlay of money. This may be cheaper in the long run, if sufficient care is taken in growing the plants. The commercial grower who self-propagates plants should make sure the source vines are true-to-name and free of atypical characteristics such as straggly clusters, very short internodes and malformed or stunted leaves that may indicate virus infection.

Appendix 1b. Growing degree days and frequency of low temperatures from various weather stations throughout West Virginia

Station ^w	Years Data ^x	GDD ^y	Average occurrence of low temperatures in 10 years ^z			
			-5° F	-6° to -10° F	-11° to -15° F	<-15° F
Gassaway	30	3469	13	11	3	1
Glenville	35	3319	24	19	7	2
Grafton	12	3061	16	13	3	2
Grantsville	21	3417	24	20	10	4
Hamilin	37	3359	19	15	6	1
Harpers Ferry	14	3683	1	0	0	0
Hastings	9	3324	11	8	2	2
Hogsett	36	3320	15	11	4	1
Huntington	27	3782	10	8	3	1
Junction	2	2899				
Kearneysville	36	3240	9	7	3	1
Keyser	5	2924	4	2	0	0
Kopperston	24	3073	11	9	3	1
Kumbrabow	11	1821	29	46	25	7
Lakin	3	3629				

Station ^w	Years Data ^x	GDD ^y	Average occurrence of low temperatures in 10 years ^z			
			-5° F	-6° to -10° F	-11° to -15° F	<-15° F
Buckeye	22	2572	53	48	25	8
Buckhannon	38	2994	31	24	9	4
Cabwaylingo	11	3396	5	5	0	0
Cacapon	13	3121	10	7	2	2
Cairo	26	3322	27	21	8	4
Canaan Valley	37	1894	58	45	21	7
Charleston	38	3759	6	5	1	0
Clarksburg	33	3185	18	14	5	2
Clendenin	2	3630	15	0	0	0
Coopers Rock	8	2374	34	31	15	5
Corton	15	3513	7	7	1	0
Cranberry Glades	7	1944	34	26	14	2
Creston	29	3251	29	24	11	5
Donlow	13	3499	11	8	4	2
Elkins	36	2500	44	38	19	6
Fairmont	38	3225	9	8	3	1
Flat Top	33	2284	28	22	8	4
Franklin	36	2822	13	11	3	0
Gary	37	3302	11	9	3	1

Hardwood Cuttings

Hardwood cuttings are the most common method of propagation. Cuttings can be made at any time after leaf drop in the fall until the sap starts to flow in the spring. If the cuttings are prepared in fall or early winter, there is a better chance of obtaining good callus formation that is critical to rapid root formation in the spring. However, good results are sometimes obtained by making cuttings a week or two before the sap rises in the spring and setting them out immediately.

Straight, vigorous, well-matured, one-year-old canes with well-developed buds should be chosen for cuttings. The best cuttings are made from canes about pencil-size or slightly larger with four buds 2-3 inches apart. This makes an ideal completed cutting 8 or 12 inches long.

In making the cuttings, a slanting cut should be made just below the lowest bud, and a straight cut should be made about one inch above the top bud so that the top can be easily identified and the bud will not dry out. Rooting takes place more readily near buds than on other parts of the cane. Usually about 50 percent of the cutting will root so take more than are required.

The completed cuttings should be grouped according to length and tied in bundles of 50 with the butt ends together. A fungicide dip is not essential but may be used to

prevent mold during storage. They should be clearly labeled, buried in trenches in a well-drained spot, butt ends up, and covered with 3 to 6 inches of soil. Inverting the cuttings induces callusing of the butt end while the top remains dormant. After the ground freezes, a covering of straw or manure will prevent alternate freezing and thawing with changes in temperature. The covering should be removed as soon as the weather warms in the spring.

As soon as the ground has become warm in the spring and there is no danger of frost, the soil should be prepared carefully to a depth of 8-12 inches and the cuttings set about 5-6 inches apart in the row and deep enough so that only the top bud protrudes above ground. The soil should then be firmed well around the cutting. Weeds should be controlled by hand, with herbicide or black plastic. Irrigation is useful and required in most years. If plastic is used, prepare the soil in ridges, cover with plastic and plant the cuttings through the plastic. Rooted cuttings can be dug in the fall, graded and stored either by setting the roots in a trench in well drained soil or storing under moist conditions at 34 F.

Layering & Grafting

Layering and grafting are sometimes used in grape propagation. Layering is used for certain varieties that do not root

readily from cuttings and for filling in vacancies in an established vineyard. Grafting is practiced chiefly by nurseries to establish a cultivar on a different rootstock and will not be described here.

In layering varieties that do not root readily, a narrow trench about 10-15 inches deep is dug in early spring where the new plant is desired or where there is room to produce a nursery plant. A healthy cane of the previous season's growth, originating close to the ground on a neighboring vine is bent down to the bottom of the trench and vertically back up to bring two or more tip buds above the soil surface. Wounding the cane opposite each underground bud will hasten rooting. The trench is then filled to promote rooting of the cane section below ground. The part of the cane connecting the new plant to the mother plant should be stripped of developing shoots as they emerge. Only the shoots from the buds of the protruding cane tip should be allowed to grow. The rooted plants can be severed from the parent vine the following spring and set in their permanent location. If the rooted plant is to fill the vacancy where it is rooted, the plant should not

be severed from the mother plant until the diameter of the new vine trunk exceeds the diameter of the bent over cane and fruit should be removed for the first two years.

Rootstocks

Grapes can be grown on their own roots or grafted onto a plant that provides special root characteristics. The primary reasons for using a rootstock are to provide resistance to phylloxera and nematode parasites on the root system, to isolate the scion cultivar from soilborne virus diseases, to induce vigorous growth in a replant situation, and to avoid varietal susceptibility to lime-induced chlorosis. If any of these situations apply to the planned vineyard site, rootstocks should be considered.

Cultivars

Grape cultivars tested in West Virginia are listed in Table 3 pages 24-27. Because of the diversity of climate in West Virginia, it is suggested that any cultivar to be planted should be tried on a trial basis first. Inclusion in this table is not an indication that the plants will survive in all locations.

Appendix 1a. Growing degree days and frequency of low temperatures from various weather stations throughout West Virginia.

Station ^w	Years Data ^x	GDD ^y	Average occurrence of low temperatures in 10 years ^z			
			-5° F	-6° to -10° F	-11° to -15° F	<-15° F
Alderson	11	2910	9	6	1	0
Arbovale	11	1962	45	36	18	5
Athens	36	2865	11	9	3	1
Bartow	6	1773	82	63	32	8
Bayard	34	2081	47	41	16	6
Beckley	24	2797	16	13	5	2
Belington	20	2606	42	34	10	5
Benson	13	3286	20	16	8	5
Bens Run	30	3158	29	22	7	1
Berkeley Springs	19	3093	6	5	2	0
Birch River	12	2375	32	28	16	4
Bluefield	28	2993	12	10	4	1
Bluestone Lake	37	3313	6	4	1	1
Brandonville	37	2439	41	34	13	4
Brownsville	4	3534	5	5	0	0

Appendices

w Weather stations are often located at airports or industrial areas that may be slightly different than town centers.

x Years data indicates the number of years of collected data these calculations are based on. The more years data, the better the accuracy. Use extreme caution when fewer than two years data used.

y Growing degree days calculated with a base temperature of 50°F.

z The average number of times these temperatures occur in 10 years. Use caution when calculations based on less than 10 years data.

Planting the Vineyard

Soil Preparation

A well-cared-for vineyard will often outlive the person who planted it. Hence, adequate soil preparation is very important. This preparation should begin at least a year before the vineyard is to be set out. It should be designed to subdue weeds, to improve the physical condition of the soil, and to add humus. This is easy to do before the vineyard is established but is difficult to do after the vines are in place. A soil sample should be taken to determine potassium, magnesium, soil pH and organic matter so that adjustments can be made before planting. The need for keeping a relatively high organic matter content in the soil cannot be overemphasized. A high humus content not only is essential for holding moisture, but it also improves the physical condition of the soil. The growing of a short season crop requiring constant cultivation, followed by a fast growing cover crop to be turned under, and augmented by the addition of as much barnyard manure as possible will put the soil in a desirable state of tilth. Part of the manure can be put on the cultivated crop in the spring, the remainder in the fall. Leave a cover crop on through the winter and turn it under in early spring. Before setting out the vineyard, poorly drained spots that show up while the cultivated crop is on the land should

be drained. If the soil is sufficiently acid to require liming, i.e., too acid for cover crop growth, lime should be applied about a year before planting. Troublesome perennial weeds such as quackgrass or morning-glory should be eliminated with herbicides before planting grapes. If grapes have been grown in this site before, at least two years of planting to grass or cover crops is required to reduce the population of grape root pests. Alternatively the site could be fumigated or vigorous rootstocks used to avoid replant growth suppression.

Layout

Several factors must be considered in deciding on the best planting distances for a vineyard. First, there should be enough space between rows to allow for convenient tractor cultivation and spraying; second, there should be enough space between plants in the row so that adjoining vines will not intermingle too much; and third, sufficient space should be allowed so that there will be little competition between the roots of adjoining plants for nutrients and water. Vines are generally set 6-8 feet apart in rows 9 feet apart. At the 8 feet spacing, 605 plants per acre will be required, at 7 feet, 690 plants and at 6 feet, 807 plants.

The first step in preparation for planting is the laying out of the vineyard. Probably the best method for

laying out a small or medium vineyard is to use a wire or cord marked by a knot at the desired intervals. By simply moving the ends of the line over the distance between rows, small marking stakes can be driven at the knots and the vineyard laid out quickly. Some growers prefer to mark off the outside rows with five- to six-foot uprights, turn furrows lengthwise and across the field, and set the plants at the intersections of these furrows. Others prefer to sight between outside stakes. Whatever method is used, it is essential that the vines be set in sufficiently straight rows so that they will not interfere with cultural operations after the trellis is in place. Adequate headland must be left at each end of the site for trellis anchoring and equipment turning.

The rows should run north and south unless there is a good reason for doing otherwise. This will lead to better light exposure, drying and disease control. The rows should not run at right angles to strong prevailing winds that might cause damage by whipping the shoots about. The vines should follow the contour of a fairly steep site, or at least run across the hill rather than up and down.

At convenient intervals a row should be left out to form an alley that will facilitate harvesting and cultural operations. The alley should divide the vineyard into blocks about twice as long as they are wide. If the field is long, 25-foot cross alleys at 1,000 foot intervals are also desirable to facilitate harvesting and fertilizing.

In West Virginia, grapes should

generally be set in early spring to avoid winter kill of fall set plants. Care should be taken to see that the plants do not dry out. When the plants are received from the nursery, the bundles should be opened and the roots soaked for several hours if they seem dry. If the ground is not prepared and cannot be prepared within a day or two, the young vines should be heeled in or held under refrigeration until ready for setting. When carried to the field, they should be kept in a pail of water or a wet sack and should not be dropped far in front of the planters. Damaged and excessively long roots should be pruned back before a vine is set.

A crew of four persons should be used for setting grapevines if possible - two to dig holes, one to hold the vine and tamp the soil, and one to backfill. The holes should be wide enough so that the roots can be spread out and deep enough for the vine to stand a little deeper than it did in the nursery row. Make sure the graft union is above ground if grafted plants are used. A little surface soil should be placed around the roots in the bottom of the hole, and the soil should be firmed as the hole is filled in to ensure good root-soil contact. Fertilizer should not be placed in the holes. After planting and after danger of frost, the vine should be pruned to one strong, two-bud cane.

Most grapes are self-fertile and bear well in isolated blocks, but a few, for example Brighton, require interplantings of pollinizers such as Concord.

Table3C. Wine Cultivars cont.

Cultivar	Color	Maturity	Vigor	Hardiness	Clusters	Cl.Size	Berries	Ripening	Black Rot	Productivity	Pruning
Leon Millot	Blue	1+	3	3	1	1+	1+	3	2	2	2
M. Foch	Blue	1	3	3	1	1	1	1	3	3	2
Niagara	White	3	3	3	3	2+	3	3	3	3	3
Riesling	White	3	1	1	1	2	2	2	2	1	1
Seyval Blanc	White	1+	2	2	3	2	1	3	2	3	1
Seyval 14117	Blue	2+	2+	2+	1	2+	2	2+	2	3	1
Vidal Blanc	White	3	3	2+	3	2	1	2	2	3	1
Horizon	White	2	2	2	3	2	2	3	2	2	1
Vignoles	White	2	2	2	1	1	1	2	1	2	1
Villard Blanc	White	3	2	2	3	3	3	1	2	2	3
Key to Table: Maturity: 1=early, 2=mid, 3=late Vigor: 1=weak Hardiness: 1=poor Clusters: 1=too tight, 2=loose, 3=full Black Rot: 1=high Productivity: 1=low Pruning: 1=short, 2=either, 3=long Berries: 1=small, 2=med, 3=large Ripening: 1=uneven, 3=uniform Cluster Size: 1=small											

Vineyard Soil Culture

Table3C. Wine Cultivars

Cultivar	Color	Maturity	Vigor	Hardiness	Clusters	Cluster Size	Berries	Ripening	Black Rot	Productivity	Pruning
Aurora	White	1	2	2	3	2	2	1	1	3	1
Baco Noir	Blue	2	3	3	1	1	1	1	3	3	3
Catawba	Red	3+	3	3	3	2+	3	1+	3	3	3
Cayuga White	White	3	3	2	3	3	3	1	2	3	3
Chambourcin	Blue	3	2+	2	3	2	2	2+	2	3	1
Chardonnay	White	3	1	1	1	1+	1+	2+	2	1	1
Chelois	Blue	3	2	2	1	1+	1+	3	2	3	2
DeChau-nac	Blue	3	2+	2	3	2	2	2+	2	3	1
Delaware	Red	3	3	3	1	1+	1	2	3	2	2
Gewurztraminer	White	3	1	2	1	1	1	2	2	1	1
Key to Table: Maturity: 1=early, 2=mid, 3=late Vigor: 1=week Hardiness: 1=poor Cluster Size: 1=small, 2=med., 3=large Ripening: 1=uneven, 3=uniform Berries: 1=small, 2=med., 3=large Black Rot: 1=high Productivity: 1=low Black Rot: 1=high Hardiness: 1=poor Cluster: 1=too tight, 2=too loose, 3=full Pruning: 1=short, 2=either, 3=long											

Weed Control

Grapevines are more shallow-rooted than trees. Consequently, they are more affected by competing weeds. To get the early vine growth needed for best yields, cultivation or herbicide strips are an established practice in commercial vineyards.

The timing of weed control or cover crop reduction between rows can be used as a tool to influence vine growth. Weed and cover crop growth reduce water availability to the vine and slow vine growth. Reducing weed and cover crop growth stimulates vine growth by increasing soil water availability. Clean cultivation will also increase temperatures around vines on frost susceptible sites.

Several herbicides are registered for use on grapes. There are three basic types of herbicides used: residual, soil-acting types such as simazine, contact herbicides such as paraquat and systemic herbicides such as glyphosate. Residual herbicides are used to control weeds before they germinate. Contact and systemic herbicides are used to control established weeds. Care must be taken to avoid applying herbicides to foliage. Consult your West Virginia University Extension Service specialist or county agent and the herbicide label for details and recommendations.

Cover Crops

One of the serious problems in the grape vineyard is the maintenance of the humus supply. Annual

cover crops will help to maintain the organic matter in the soil. Humus may also be increased by applying barnyard manure, waste hay, straw and pomace plus stems with the chopped prunings.

A cover crop lessens soil erosion and the leaching of valuable soil nutrients and it promotes earlier hardening of wood in short-season locations. In the bearing vineyard the cover crop should be sown at the last cultivation in August. Domestic rye grass, rye, wheat, barley and vetch are commonly grown. If the cover crop is sown under the trellis, perennials such as rye may become a weed problem. Cold-susceptible covers are useful in these situations.

Complete commercial fertilizers may be used to get a good cover crop. An application of 100-250 pounds of a 10-20-10 fertilizer per acre is recommended for small grains such as rye, and 150-200 pounds of a 0-20-10 fertilizer for legumes.

The Hillside Vineyard

A system of clean cultivation is difficult to carry out in vineyard located on hillsides. Some early spring cultivation may be given in such vineyards if rows have been laid out on the contour system and if some terracing was done. If much soil erosion occurs, mowed sod cover should be planted every row or every alternate row depending on vine size and vigor. Within the row the soil should be cultivated or weeds controlled with her-

bicides. The more sod, the greater the reduction in vine growth. On less steep slopes, trashy cultivation may be the best alternative. In this method a disc or rotary mower is run through the vineyard often enough to keep the weeds and grass from competing with the grapes, but the ground is never left bare. In general, fruit production will not average as high from hillside vineyards as from those on more level land because it is more difficult to thoroughly cultivate hill-sides. Where mulching materials are cheap and plentiful, mulching may be the best method of soil management in hillside vineyards.

Fertilizer

Soil fertility should be determined from soil sample analysis prior to planting. After planting, soil tests are not a dependable method of identifying nutrient deficiencies. The nutritional status of the vines can best be determined from petiole analysis after planting. Petioles (leaf stems) are collected from the youngest mature leaves of exposed bearing primary shoots during August. They sample should reflect typical vines. If some vines are showing symptoms of nutrient deficiencies, these should be sampled separately. Contact the extension agent or specialist for further information on collecting petiole samples. A history of fertilizers applied and petiole analysis results are useful in deciding on future fertilizer applications.

Soil fertility in the vineyard may be best maintained by the use of manure and pomace when used at rates of 5-15 tons/acre. Some form of commercial fertilizer should be used if

there is insufficient manure. Nitrogen is generally the element lacking; hence, marked responses will be obtained by applications of urea, ammonium sulfate or ammonium nitrate. Cost per unit of nitrogen should determine the selection of the form used. Forty to 60 pounds of actual nitrogen per year is a general recommendation, and applications should never be greater than 80 pounds actual nitrogen per year. A 200-300 pound application of ammonium sulfate per acre (about one-half lb. per vine) made in the spring is an average recommendation for vine maintenance on high-lime soils. Nitrogen fertilizer should be applied 2-3 weeks before the anticipated bud break so that there is sufficient nitrogen in the plant for strong growth at bud break. After establishment of vine size, apply fertilizers only as recommended by tissue analysis.

Complete fertilizers should be used on the cover crop only, as potassium and phosphorus need only be applied to the grapes when tests indicate they are lacking. Potassium, magnesium or manganese deficiencies should be corrected as soon as discovered with rates of fertilizer determined by the severity of the symptoms. Petiole analysis can detect incipient deficiencies so they can be corrected before symptoms appear.

In new plantings, a fertilizer such as ammonium sulfate should be spread uniformly in a circular area around each vine, starting a few inches from the trunk and extending out to a distance of a few feet. Broadcast applications may be used after the first year, as vine roots extend throughout the soil volume.

Table 3B. Seedless Table Cultivars

Cultivar	Color	Maturity	Vigor	Hardiness	Clusters	Cluster Size	Berries	Ripening	Black Rot	Productivity	Pruning
Canadice	Red	1	2	2	1	2	1+	1	2	1	1
Concord, Sdls	Blue	2+	2	2+	2+	2	2+	2	3	3	2
Glenora	Blue	1+	3	3	1+	2+	2	3	2	2	2
Himrod	Blue	1	2	1	2	2+	2+	2+	2	2	2
Interlaken	White	1	2	2	3	3	2+	3	2	3	2
Lakemont	White	1	2	2+	3	3	2	3	3	3	2
Remaily	White	1+	2	2	3	2+	2	1+	2	3	2
Romulus	White	1+	2	1	2	2	2	3	2	2	2
Suffolk Red	Red	1+	2	2	2	2+	3	1	2	2	2
Venus	Blue	1+	2+	2	1	2+	2	3	2	2	2
Key to Table:			Vigor: 1=weak			Hardiness: 1=poor			Clusters: 1=too tight, 2=loose, 3=full		
Maturity: 1=early, 2=mid, 3=late			Ripening: 1=uneven 3=uniform			Black Rot: 1=high			Productivity: 1=low		
Cluster Size: 1=small			Berries: 1=small, 2=med, 3=large			Pruning: 1=short, 2=either 3=long					

Table 3. Summary of grape cultivar characteristics in trial at Kearneysville, WV (1986-1989).

Table 3A. Seeded Table Cultivars

Cultivar	Color	Maturity	Vigor	Hardiness	Clusters	Cluster Size	Berries	Ripening	Black Rot	Productivity	Pruning
Buffalo	Blue	2+	3	3	2	2+	3	2	3	3	3
Concord	Blue	2+	3	3	2+	2	3	2	3	3	2
Festivee	Blue	1+	2	1	2+	2	2+	3	2	2	2
Fredonia	Blue	1+	3	3	3	1	3	3	3	2	2
Kay Grey	White	1	3	3	1	1	2	2	1	2	2
Monticello	Red	2	2	2	3	2+	2+	3	2	2	1
St. Croix	Blue	11	3	2	2	1	1	3	2	2	2
Key to Table: Maturity: 1=early, 2=mid, 3=late Vigor: 1=weak Hardiness: 1=poor Clusters: 1=too tight, 2=loose, 3=full Black Rot: 1=high Productivity: 1=low Pruning: 1=short, 2=either, 3=long											

Training and Pruning

Before attempting to train or prune a grapevine, certain principles must be understood to achieve the desired results. Pruning is the removal of wood to regulate fruit production. Training is the removal of wood in such a way as to shape the vine so that it will bear a good crop without breaking and will not interfere with cultural operations.

Grapes are vigorous plants that require the removal of 80-90 percent of the new wood after establishment to balance fruiting and vegetative growth. All pruning should be done while the vines are dormant, preferably a short time before the sap begins to circulate in the spring. Winter-injured wood may then be identified and removed.

Training Young Vines

First year: Prune back to four buds at planting. After danger of frost, cut back to two living buds.

Second year: During the dormant season following the first growing season, a single good cane should be chosen to form the main trunk and attached to the top wire if possible. When the buds burst, 6 to 10 shoots should be retained on the upper portion of the trunk if training systems such as umbrella Kniffin, Hudson River umbrella, or Geneva double curtain are being considered, or at the proper position for arms or other training systems. All other shoots should be removed to concentrate growth in the canes desired for future training. All flower clusters should be removed as they develop to allow the plant to become established before bearing a crop.

Third year: Vines that produce 3/4 pounds or more of pruning should be balance pruned and fruited in the third year. Flower clusters should be thinned to one per shoot to prevent over cropping. If

vines do not produce 3/4 pounds of prunings, the recommendations for the second year training should be repeated.

A second cane originating from the very base of the vine can now be retained and pruned to the bottom wire if a double trunk system is desired for areas with frequent winter injury. In these areas the training systems are done with two trunks. If one trunk is killed by winter injury, mechanical damage or eutypa die-back disease, it can be removed with little effect on production. During the third growing season, all but two or three shoots near the top of this cane should be removed shortly after shoot growth commences. In later years this second trunk is pruned as a mirror image of the other trunk and both are considered as one plant in counting buds.

Principles

The principles of pruning indicate what wood to leave, how much to leave, and where to leave it on mature vines. In brief they are as follows:

1. The fruit is borne on shoots produced from one-year-old wood. One-year-old wood is brown, reddish-brown, or gray, depending on the variety, and the bark is tight and not peeling. The amount of wood older than one year should be kept to a minimum to form the framework for holding the fruiting wood.

2. Severe pruning results in an excess of wood and little fruit, although both berries and clusters will be large. Light pruning results in the production of little wood and a large number of small clusters of small fruit. A balance between wood and fruit production is desired to give a good crop of large clustered fruit and enough wood for good canes the following season. The number of buds to leave is cultivar dependent. For most cultivars 30 buds should be left for the first pound of one-year-old wood prunings removed and 10 buds left for every pound of prunings after that. If you remove 3 pounds of one-year-old wood, then there should be 50 buds left on the vine. These 50 buds may be ten 5-bud spurs or five 10-bud canes depending on your training system. This allows a balance that will vary with the vigor of the plant. To do this, most of the wood is removed, leaving more than you think should be left. After weighing what has been taken off, the buds remaining can be counted and more wood pruned off to adjust the number of buds remain-

ing to fit the balanced pruning equation.

3. The best canes to keep for fruiting are those of medium size (about the size of a pencil) with plump buds. Canes with a diameter of one-fourth to one-third inch and an internodal length of five to eight inches (internode lengths are shorter on vinifera and French hybrid cultivars)- both measured between the fifth and sixth nodes from the base - are considered ideal.

4. The most productive buds on the canes are cultivar dependent, but generally the third to ninth buds will produce shoots with the most flowers.

5. The bearing wood should be close to the main trunk. This saves space and limits the uptake of plant food by unfruitful wood. Choose wood and renewal spurs (canes pruned to 2-3 buds to provide canes for fruiting the next year) close to the permanent training structure. Permanent structures include the main trunk and branches (short arms or long cordons) that the fruiting wood originates from.

Flower-Cluster Thinning _____

Flower-cluster thinning is the removal by hand of some of the flower clusters on each shoot to control crop load. This is most effectively done when the clusters first appear. Clusters are removed to increase the vigor of very weak vines and to reduce excessive crops on vigorous vines.

cause contact insecticides are ineffective against subterranean larvae. An effective cultural control method involves mounding soil beneath vines after borers have pupated, and then leveling the ridges in the fall or spring. When adults leave the cocoons they are unable to dig to the surface. Timing is important because if mounding is done too early the larvae merely tunnel up into the ridge before pupating. Proper weed control appears to be important in borer management because of increased larval mortality at the exposed soil surface. Nitrogen fertilizer may help the vines overcome some of the effects of damage.

Other Disorders _____

Nutrient deficiencies can stunt, yellow, blacken, scorch or kill grape leaves. Symptoms can be used to identify the deficient element; however, petiole analysis is best used to confirm a suspected symptom. The extent of the deficiency is gauged by the time at which the symptoms appear and by their severity. Growers should be familiar with the leaf symptoms of deficiencies of nitro-

gen, potassium, magnesium, and manganese and should closely inspect their vineyards in late August or early September to determine whether symptoms are present. Consult your extension agent or specialist for assistance in identification.

Nitrogen deficiency is seen in reduced vine size and small, pale leaves. *Potassium* deficiency is seen in interveinal or marginal chlorosis or both. With increasing severity, marginal necrosis (scorch) develops. *Magnesium* deficiency appears first and is most severe on basal leaves of the shoots. *Magnesium* deficiency is usually indicated by chlorosis between the large veins; however the veins remain green and there is usually a thin line of green tissue at the margin of the leaf. When severe, the tissue between the veins can become necrotic and easily confused with potassium deficiency. *Manganese* deficiency is indicated by intermittent interveinal chlorosis which is usually more severe on shaded leaves than those in full sun.

pal stage on fallen leaves. It emerges about the time the grapes are blossoming. There are two broods. The first eats the stems and external portions of the young berries. The caterpillars of the second brood live entirely in the berries. They attack all cultivars. They are most injurious to those cultivars that have compact clusters since they tend to be protected in such clusters and can feed readily on more than one berry. Some of the injured grapes fall from the clusters; the rest must be discarded at harvest time. Spraying is the best control, but deep cultivation of the leaves in late fall or early spring also aids in control. For a few vines, it often pays to pick and destroy the berries infested by the spring brood and to rake and burn the leaves in the fall to reduce the overwintering population. Populations may be monitored with a commercially available pheromone trap. *Trichogramma minutum* Riley is an egg parasite that will provide some biological control.

The **rose chafer** (*Macrodactylus subspinosus* (Fabricius)) may be very bad in some seasons, especially where there is light, sandy soil nearby. It is a long-legged, yellowish-brown beetle about one-third inch long. It may appear in vast swarms about the middle of June or earlier. It stays about a month and eats foliage of all kinds in gardens, vineyards and orchards. The larvae feed on the roots of grasses in sandy soil. Consequently, if most of the surrounding land is under cultivation, the number of chafers may be kept down. Cultivation also destroys some of the

pupae. Petal-fall sprays for grape berry moth will also control rose chafers.

The **Japanese beetle** (*Popillia japonica* (Newman)) is a shiny metallic-green beetle less than half an inch long with coppery-brown front wings. It is of considerable importance in parts of West Virginia. It usually appears between June 1 and 15, and may be present until mid-August or later. Grape leaves are among its favorite foods, and unless protected many of the leaves may be reduced to a lace-like skeleton. The eggs are laid in the soil in grassy areas and the grubs develop there. The larvae may be controlled by a bacterium, *Bacillus popilliae* (milky spore). This biological control agent is applied to grassy areas to control large larval populations, but is not effective against adults. Commercially available attractant traps are generally not adequate to protect vineyards, but can be useful in monitoring populations. Insecticide applications will usually be necessary for control of the adults.

The **Grape root borer** (*Vitacea polistiformis* (Harris)) can cause extensive damage to a vineyard before its presence is even detected. Although inconspicuous, the larval feeding can result in yield losses and death of the vines. The borers, which are white with brown heads and range in size from less than an inch to two inches, feed beneath the outer bark of the roots. The adults, unlike most moths, fly only during the day, and often escape identification because they resemble wasps. Control of this pest is difficult be-

Early reduction in crop load will allow the remaining fruit to be larger, ripen earlier and have higher sugars than fruit on over cropped vines. Clusters are usually thinned to one cluster per shoot.

Growth regulators are also used to control fruit size. Gibberellic acid is a natural plant hormone usually produced by seeds. Most seedless grapes respond to gibberellic acid with an increase in berry size. In some cultivars, such as Canadice, the increased berry size can result in excessive compactness and berry cracking. Concord seedless also reacts unfavorably. Gibberellic acid is applied at mid bloom and at fruit set, usually about 7-10 days after bloom, to reduce berry number and increase berry size.

Seeded grape cultivars may respond to gibberellic acid with reduced cluster compactness and therefore a reduction in bunch rot in cultivars with very compact clusters. In seeded grapes, gibberellic acid is applied when shoots are 4 to 6 inches long. Consult the label before use because some seeded cultivars vary in their response to gibberellic acid. Misapplication of gibberellic acid can result in increased winter damage and reduced bud fruitfulness in the year following application. Label recommendations should be strictly followed.

Systems

There are many different ways to train grape vines. Research and experience have shown that the Judson River umbrella or Geneva double curtain are best for medium to large vigorous vines of Concord and similar varieties. Four arm Kniffin, cordon and other training systems are acceptable for smaller vines. In choosing which system, several considerations should be kept in mind. Vines that are trained on two wires, one above the other, will have less growth and lower yields on the lower wire because of shading from the canes above. Renewal spurs should be in high light environments to produce good canes for the next year's crop. Cultivars with large leaves and drooping shoots, such as Concord, Niagara, and Fredonia, should have the head or renewal area of the vine at the top wire to get the best light exposure. Cultivars with upright shoots and small leaves can better tolerate having the renewal area at the middle wire of a three-wire trellis because there is less shading. Cane bending as used in umbrella Kniffin will increase bud break along the canes or vigorous vines, but should not be used with weak vines of any cultivar. In all systems, the foliage should be uniformly distributed along the trellis and over its full height to a depth of not more than one and one-half to two layers of leaves for effective exposure to sunlight.

Geneva Double Curtain:

This system utilizes a 4-foot cross arm on the trellis to double the amount of canopy per row and a single wire about 3 feet high to support the trunk (Fig. 1). Vines are trained to alternate sides of the 6-foot high trellis. Each vine has a 6-8 foot cordon (permanent branch on either side of the main trunk, or trunks that is secured by two to four wraps around the support wire with a wire tie at its end. Each cordon has 10-12 short (4-6 bud) canes evenly spaced along its length. A renewal spur should be kept as next year's replacement for each of the short canes.

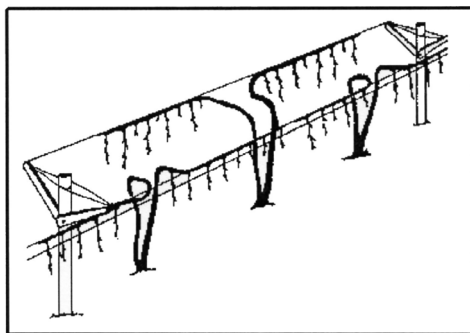

Figure 1. Geneva double curtain training system

Four Arm Kniffin: This system utilizes two wires at 3 and 6 feet from the orchard floor (Fig. 2).

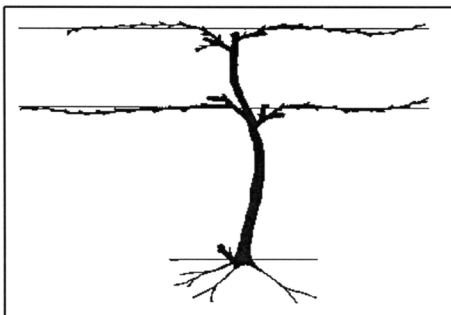

Figure 2. Four-arm Kniffin training system.

At pruning, four canes and four renewal spurs should be retained. The canes should originate a few inches below the wire they are to be trained on and be 8-12 nodes long. Two to 6 canes may be retained depending on variety, can vigor and vine spacing.

Umbrella Kniffin: This system uses the same trellis as the four arm Kniffin; however, the canes all originate from the head or top of the vine (Fig.3). The top of the vine should reach to 6-12 inches below the top wire. From this head region, one to six canes of 8-15 buds are bent sharply over the top wire and tied down to the lower wire. Each cane retained should have a renewal spur retained nearby on the head of the vine.

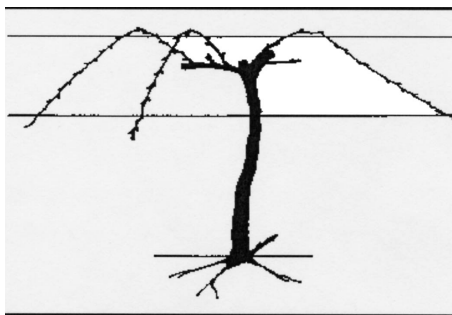

Figure 3. Umbrella Kniffin training system.

Deer

In areas with adjacent woodlands, deer can cause significant damage to the vines and foliage. Many repellents have been tried, but none is completely successful. Fencing is the most effective method of keeping deer out of the vineyard. There are several fence design alternatives from low cost electric spider fences, to 6 wire electric fences or 8-foot high or higher nonelectric fences. See "Deer and Agriculture in West Virginia," Publication 809-810, for more information.

Diseases

Black rot (*Guignardia bidwellii*) is the most important disease of grapes in West Virginia. The fungus attacks the leaves, stem and tendrils in the spring. Early symptoms of the disease are small brown or black spots that cause no serious damage and are seldom noticed. Later the fungus spreads to the fruit, where it is still not noticeable until the berries are about half grown. Between this period and fruit ripening the severity of the disease increases very rapidly and the fruit finally turns black and shrivels. The disease overwinters in those shriveled berries (mummies) and on the dead tendrils and canes, so these should be removed and destroyed at pruning time. Careful spraying will keep this disease under control.

Botrytis (*Botrytis cinerea*) is the other major fungus that will attack fruit. Infection first occurs during flowering and is not apparent until later in the season. Single berries will turn brown and rot. Spore masses are a characteristic gray that will cover the affected area. Sporulation is enhanced by rain, free moisture on the berries

and high humidity (above 92%). The fungus will not grow at temperatures above 94oF. The fungus overwinters in the infected berries or clusters and spores are spread by air after moist weather in the spring. Botrytis is best controlled by an integrated program. Reduce overwintering inoculum by removing grape mummies at pruning and discing them under. Fungicides at bloom time are most effective. Vines should not be sprinkler irrigated once the fruit begin to ripen to avoid moisture on the berries. An open canopy that allows air circulation will also keep fruit drier and reduce infection conditions.

Powdery mildew and other fungus diseases are controlled by fungicides applied at regular intervals.

Insects

The **grape leafhopper** (*Erythroneura spp.*) is a small, light-green, sucking insect that can be found in almost all vineyards from late May and early June until fall. Adults have red, yellow or black markings and overwinter in dead grass, under leaves, or in rubbish piles. They emerge as soon as it is warm in the spring. They live on strawberry, blackberry, and raspberry leaves until the grape leaves open. They suck the sap through the lower surface of the leaves and cause small, pale spots to appear. When the insects are numerous, the leaf has a mottled appearance and may eventually dry up and fall. Cleaning up rubbish piles and spraying will help control this pest.

The **grape berry moth** (*Endopiza viteana* Clemens) is the worm usually found when grapes are wormy at harvest time. It is a dark-colored caterpillar. It passes the winter in the pu-

Harvesting

Grapes should be picked when the fruit reaches the desired ripeness for its intended purpose. As the fruit ripens, the color changes, the sugars increase and the acids decrease. The timing will vary from year to year. Berries should be sampled daily as the harvest approaches to determine sugar, acid and pH. To sample, randomly collect 100 to 200 representative berries for each cultivar. Acids decrease rapidly under warm conditions and fruit quality can change rapidly.

To harvest the grapes a grape knife or harvesting shears are used. Hold the grapes with one hand and cut with a rapid upward cut away from your hands and arms to prevent injury. Hand shears are safer but are slower and more difficult to use. Do not jerk or pull clusters from the vine as this will crush some of the fruit. Discard all green, immature or dis-

eased fruit. Gently place the fruit into harvesting lugs or boxes and handle as little as possible. Take the containers into the shade as soon as possible to reduce fruit temperatures. Grapes should be taken to the winery the same day they are picked.

Grapes will keep several weeks after maturity on the vine or if picked and stored in a very cool, dry, well-ventilated place. As long as there is no dropping of the berries it is best to leave the crop on the vines and pick as the market demands. Unless weather is rainy, there will be no deterioration. If well-protected by foliage, grapes will stand cold weather (but not a frost). However, birds and bees molesting the crop must be considered in the decision as to whether or not the mature crop is left on the vine.

Pest Management

Birds are common problems in vineyards. They may eat the entire berry or damage the fruit by clawing or pecking. The severity of damage is related to cultivar, degree of ripeness, amount of foliage hiding the fruit and proximity to bird roosting sites. Small isolated vineyards with early ripening cultivars are the most susceptible to damage. Monitor bird damage as the fruit begin to change color. Early detection is critical in control efforts. Many systems are available to control birds, but none is completely successful.

Shotguns are one method of controlling birds, however many birds are protected by law. Gas exploders and electronic noise-makers, if moved about the orchard frequently, have similar effects. Other scare devices such as hawk kits, scare eyes, distress tapes and bird bombs can be used in combination with gas cannons to improve their effectiveness. Bird netting is the most effective method for controlling birds, but is expensive and cumbersome.

Bilateral Cordon: This system is similar to the Geneva double curtain only it is a single curtain (Fig. 4). In this system the main vine is trained up to the top wire and two cordons are trained out from it toward the adjacent vines. Each cordon is three to four feet long and has 5-6 short canes or spurs that can be summer tied to the lower wire if needed. The cordon should also have an equal number of renewal spurs spaced along its length.

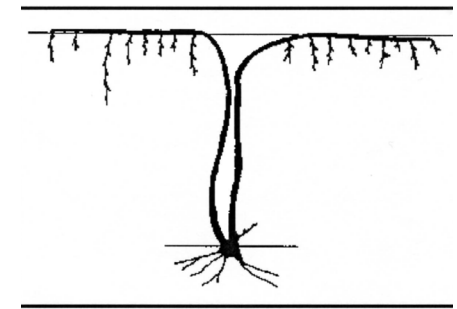

Figure 4. Bilateral Cordon training system.

Trellising

Two-Wire Vertical Trellis for Grapes

The basic two-wire trellis is 5 feet high and is designed mainly for the four-cane kniffin system. Single-span brace or tie-back assemblies may be used. Wire spacing from the ground up is 30 and 28 inches. Line post spacing is 20 to 30 feet. High tensile 200,000 PSI 12 1/2 gauge fence and trellis wire tensioned to a minimum of 250 pounds can provide adequate support for trellis lengths up to 4,000 feet. Properly constructed end brace assemblies are a must for any grape trellis, but become more important as the trellis length increases.

General trellis component specifications are given in Figure 5. The trellis can also be constructed with different size posts, number of wires and post spacings to accommodate heavier fruit loads.

The end post in the tie-back

brace assembly is driven at a 30-degree angle from vertical, opposite the direction of pull of the line wires. For a 58-inch high trellis a 4-inch diameter, 9 foot long post should be used in unstable soil, an 8 foot post in stable soil. The angle to drive the post can be determined by setting the post vertically at ground level and marking a 58-inch height on the post. Attach a plumb line at this mark and lean the post until the plumb line is 32 inches (horizontally) away from the post. The post is driven at this angle until the top is 58 inches (vertically) above the ground.

The 6-foot long x 4- to 5-inch diameter tie-back post is driven vertically to a 4- to 5- foot depth at a 28-inch horizontal distance from the plumb line location. With the line wires attached to the tie-back post 6 inches above ground, the end post, top line wire and horizontal projection of the two line wires from the tie-back post toward the end post form an equilateral triangle.

Two-Wire Vertical Trellis for Grapes

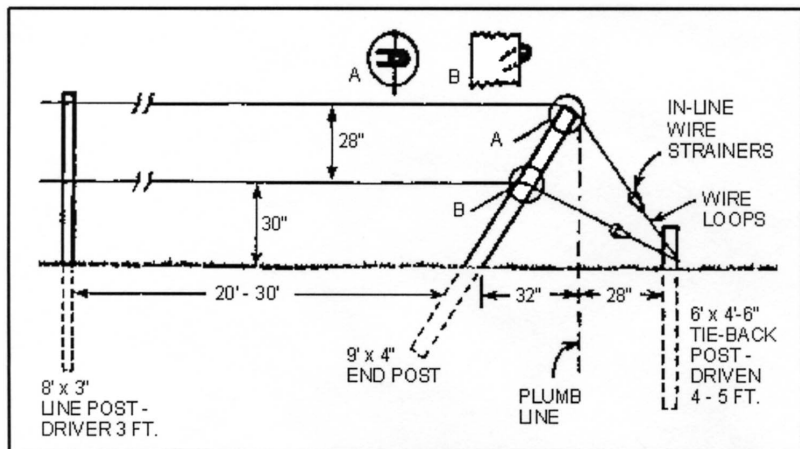

Figure 5A. Two-wire vertical trellis for grapes. Revised from How to Build Orchard and Vineyard Trellises, Kiwi Fence Systems, July 1982.

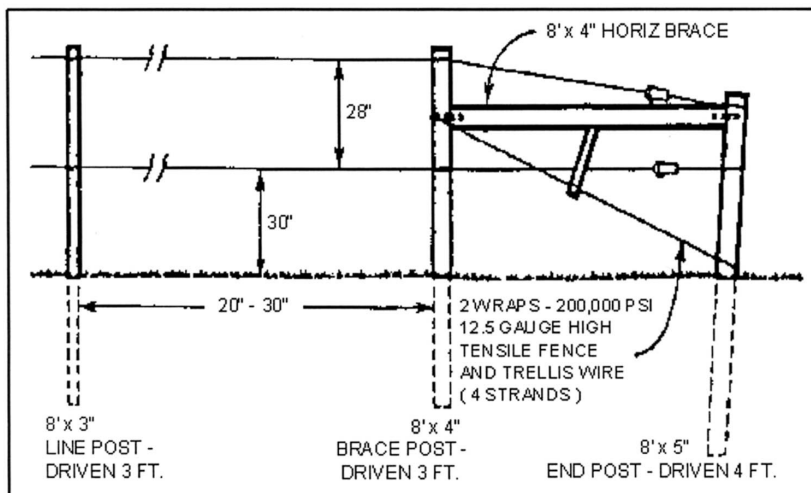

Figure 5B. Two-wire trellis for grapes. Revised from How to Build Orchard and Vineyard Trellises. Kiwi Fence System, July 1982.

Geneva Curtain-Type Trellis for Grapes

The Geneva Curtain trellis is a three-wire T-shaped trellis designed for high production and mechanical harvesting, usually on relatively flat terrain. Single span brace or tie-back assemblies properly constructed can support trellises up to 4,000-foot length. Line posts spaced 20-30 feet apart, depending on terrain, provide support for the 12-1/2 gauge high tensile support wires.

Wire spacing from the ground up for the vertical support wires

is 26, 26 and 20 inches. A 4-foot long cross-arm is used to support two upper support wires placed 22 inches out from the post. These upper support wires are at a 72-inch height above ground. All wires are tensioned to a minimum of 250 pounds. Line posts should be placed closer together on rolling terrain to maintain a uniform wire height.

General trellis component specifications are given in Figure 6. The trellis can be modified to accommodate different requirements.

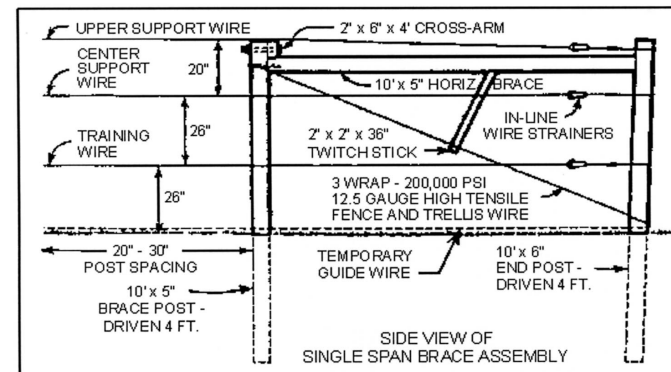

Figure 6A. Geneva Curtain-type trellis for grapes.

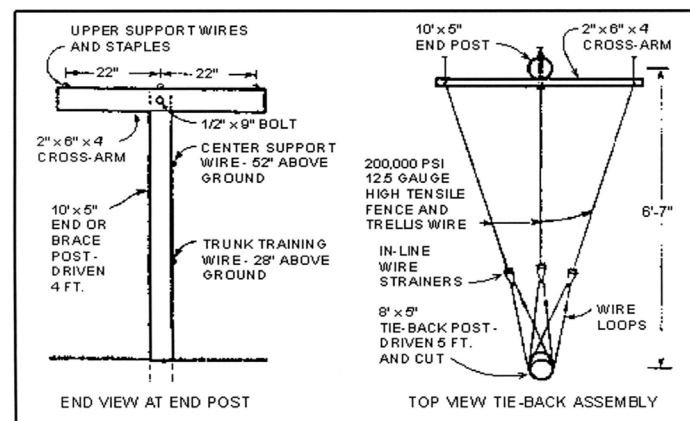

Figure 6B. Geneva Curtain-type trellis for grapes.